

# Accurate Time & Frequency system for military applications

Use as an accurate Time & Frequency center  
for military platforms

The **AR51A-09** unit is a compact GPS-Disciplined Rubidium Clock, which offers an excellent stability and accuracy. The unit includes a Rubidium-Atomic-Standard, which is phase-locked to the disciplining source (like GPS or other external inputs).

**All outputs are derived from the Rubidium-Atomic-Standard and maintain highly accurate time and frequency even when GPS reception interrupted.**

## Key Features

- GPS disciplined Rubidium clock
- Frequency Accuracy : 1E-12
- 1PPS Accuracy: 30ns (RMS)
- Multiple outputs: 10MHz, 1PPS, TOD (Time of Day)
- TOD protocols: Have Quick, CLI
- Inputs: GPS antenna, 1PPS, TOD
- Holdover (no GPS): 1 $\mu$ s/24 hrs (typ.), 5E-11/month
- Monitor & Control: RS232 / RS422
- C/A code GPS receiver
- MIL-STD qualification for airborne applications
- Compact: 175 mm (d) x 132 mm (w) x 56 mm (h)

## Options

- P(Y) code GPS (SAASM) receiver
- TOD : NMEA, NTP / PTP, IRIG B
- Monitor & Control: LAN (UDP, SNMP)
- NTP Client (Option)



**For Airborne, Ship borne & Land platforms**

## Description

The **AR51A-09** includes Time of Day (TOD) inputs and outputs. The standard unit include several Have Quick (ICD-GPS-060) Time Code outputs, followed by several (more than 20) 1PPS outputs (PTTI ICD-GPS-060, TTL and RS-422 formats) for accurate timing which is essential for secure radio communication applications. The standard unit includes also Have Quick (ICD-GPS-060) Time Code input for initial time loading followed by 1PPS input for the 1PPS timing synchronization, when the GPS signal is not available.

The communication with the unit is the CLI (Command Line Interface) by RS-232 or RS-422. The CLI outputs provides Time, Navigation and status data. The unit can be configured by CLI input channel.

Other Time of Day formats are available as an option like NMEA, IRIG B, NTP or PTP.

The AR51A-09 can be synchronized from 3 independent inputs: internal GPS, external GPS and other external independent accurate timing systems. The input synchronization source is selected manually by user or automatically.

Standard option of the unit is LAN interface, which include NTP (Network Time Protocol), and Monitor & Control by UDP or by SNMP.

The AR51A-09 is designed for demanding military platforms such as fighter aircraft, helicopters, UAV's, ship borne, submarine and mobile land platforms. The unit is designed for quick installation on a tray or hard mount installation with screws.

All specs are @ 25°C, quiescent conditions and sea level ambient unless otherwise specified

# Specifications

| Input & Outputs                |  |   |
|--------------------------------|--|---|
| <b>Outputs (*)</b>             | 10MHz, Sine wave (8±3) dBm / 50W (x 1)   |   |
|                                | 1PPS TTL/50Ω (x 2)   |   |
|                                | 1PPS RS-422 (x 5)  |   |
|                                | 1PPS PTTI (ICD-GPS-060)/ 50Ω (x 17)  |   |
|                                | TOD Have Quick (ICD-GPS-060) / TTL 100KΩ (x 4)   | Options: NMEA, NTP server V3 per RFC1305 ≤ 1ms, IEEE 1588 (PTP) – Grandmaster, IRIG B |
| H/W BIT (open collector) (x 1) |  |   |
| <b>Inputs</b>                  | TOD Have Quick (ICD-GPS-060) / TTL 100K Ω (x 1)  | Options: NMEA, IEEE 1588 (PTP) – Slave, IRIG B  |
|                                | 1PPS TTL/50Ω or PTTI, ICD-GPS-060/ 50Ω (x 1)   |   |
|                                | 1PPS RS-422 (x 1)  |   |
|                                | GPS Antenna  |   |
| <b>CLI Communication</b>       | CLI – Command Line Interface, RS232 or RS422 for status monitoring and control for unit configuration<br>Baud rate: 19,200, Control: 1, N, 8 | Options: LAN – UDP & SNMP, MIL- STD-1553RT (Mux-Bus)                                  |
| <b>MIL-GPS keys</b>            |  | Option: P (Y) code GPS receiver cryptokeys  |

(\*) For other outputs contact factory.

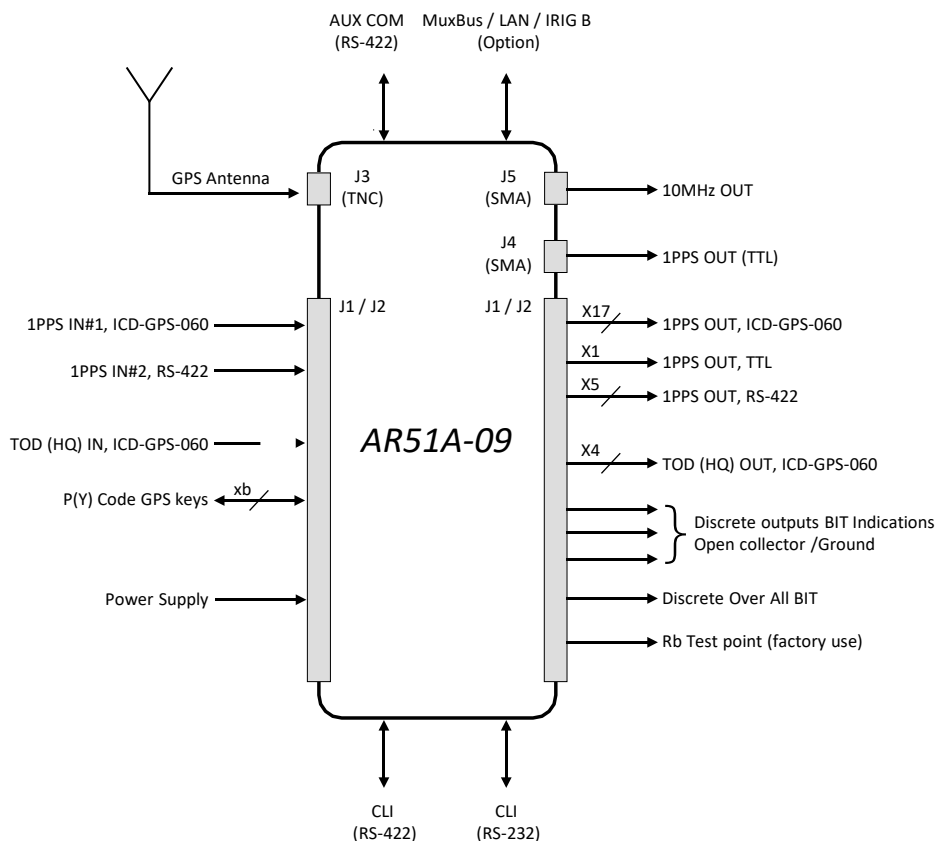

All specs are @ 25°C, quiescent conditions and sea level ambient unless otherwise specified

## Electrical Interface

| Performance                                       |  |   |                                     |                               |
|---|--|---|-------------------------------------|-------------------------------|
| Time (1PPS)                                       | Long- Term Accuracy  | Disciplined to GPS or to an external synchronization source                                 | 50ns RMS @ 25°C (Typical: 30ns RMS) |                               |
|   |  | Time drift without GPS (Hold-Over)  | < ±1µs/24hr (typical)               |                               |
| Frequency (10MHz)                                 | Frequency Accuracy   | Disciplined to GPS or to external 1PPS  | < ±1E-12 (24 hours average)         |                               |
|   | Long Term stability  | Frequency drift without GPS (Hold-Over / Aging)   | ±5E-11 / month                      |                               |
|   | Short Term Stability (ADEV)  | ≤ 3E-11 @ 1s  |                                     |                               |
|   | Temperature Stability  | ≤ ±3E-10 over -25°C to +65°C (relative to +25°C)<br>(-40°C to +71°C available as an option) |                                     |                               |
|   | Phase Noise  | <b>Offset frequency [Hz]</b>  |                                     | <b>Phase noise [dBc / Hz]</b> |
|   |  | 10Hz  |                                     | ≤-114 dBc/Hz                  |
|   |  | 100Hz   |                                     | ≤-140 dBc/Hz                  |
|   |  | 1KHz  |                                     | ≤-140 dBc/Hz                  |
|   |  | 10KHz   |                                     | ≤-150 dBc/Hz                  |
|   | Harmonics  | ≤-53 dBc (up to 90MHz)  |                                     |                               |
| Spurious  | ≤-100 dBc @ ± 100KHz from carrier  |   |                                     |                               |
| Warm-up (accuracy vs. time)                       | Rb Lock (< 1E-9 ) < 5 min<br>±5E-10 within < 7 min<br>±5E-11 within < 60 min<br>±1E-11 within < 4hrs<br>±1E-12 within < 24 hrs |   |                                     |                               |
| Retrace (without GPS or other disciplining input) | ± 5E-11  |   |                                     |                               |

| GPS Receiver                   |  |   |
|--------------------------------|--|---|
| GPS Type                       | C (A) Code GPS receiver  | P (Y) Code GPS receiver (option)  |
| GPS Tracking                   | L1 frequency 1575 MHz C/A code (SPS)12 parallel tracking channels. | L1/L2 frequency P(Y) code SAASM 12 parallel tracking channels   |
| Ephemeris & Almanac            | Available (Option)   | ---   |
| Position Accuracy              | Latitude, Longitude: < 6m (CEP 50%)<br>Altitude: < 11m (CEP 50%)   | PPS: < 12 m CEP   |
| Acquisition Time (Typical) (*) | Warm start ≤ 45 second<br>Cold start ≤ 50 second (worst case)      | Warm start ≤ 1 min (worst case)<br>Cold start ≤ 12.5 minutes (worst case)<br><br>≤ 30 seconds when receiving the same satellites constellation (warm or cold start) |
| Internal backup battery        | N / A  | Keeping Ephemeris & Almanac. The receiver uses the battery for saving the data for non-operating accumulative duration of about 2years.                             |
| GPS Antenna DC Voltage         | 5VDC (up to 100 mA)  |   |

The P (Y) code GPS receiver must be supplied by user

All specs are @ 25°C, quiescent conditions and sea level ambient unless otherwise specified

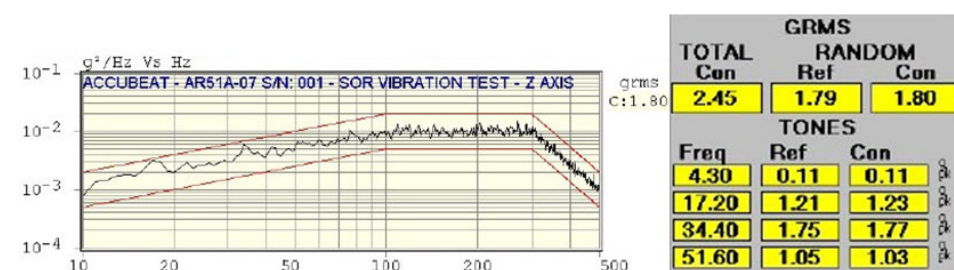
| <b>Environmental</b>                |   |               |  |  |              |               |               |      |      |      |       |  |  |      |     |     |      |      |      |       |      |      |       |      |      |       |      |      |
|-------------------------------------|---|---------------|--|--|--------------|---------------|---------------|------|------|------|-------|--|--|------|-----|-----|------|------|------|-------|------|------|-------|------|------|-------|------|------|
| <b>Temperature</b>                  | <b>Operating</b> :-25°C to +65°C (option for -40°C to +65°C)<br><b>Emergency:</b> +71°C for 30 minutes<br><b>Storage</b> : -40°C to +85°C (option: lower storage temperature of -46°C. Been tested in modelAR51A009-W0L00)  |               |  |  |              |               |               |      |      |      |       |  |  |      |     |     |      |      |      |       |      |      |       |      |      |       |      |      |
| <b>Temperature Altitude</b>         | 0 to 50,000 ft  |               |  |  |              |               |               |      |      |      |       |  |  |      |     |     |      |      |      |       |      |      |       |      |      |       |      |      |
| <b>Humidity</b>                     | 95% non condensing  |               |  |  |              |               |               |      |      |      |       |  |  |      |     |     |      |      |      |       |      |      |       |      |      |       |      |      |
| <b>Random Vibration</b>             | 2.45gRMS as per the following profile:<br> <table border="1" style="margin-left: auto; margin-right: auto;"> <thead> <tr> <th colspan="3" style="text-align: center;">GRMS</th> </tr> <tr> <th style="text-align: center;">TOTAL<br/>Con</th> <th style="text-align: center;">RANDOM<br/>Ref</th> <th style="text-align: center;">RANDOM<br/>Con</th> </tr> </thead> <tbody> <tr> <td style="text-align: center;">2.45</td> <td style="text-align: center;">1.79</td> <td style="text-align: center;">1.80</td> </tr> <tr> <th colspan="3" style="text-align: center;">TONES</th> </tr> <tr> <th style="text-align: center;">Freq</th> <th style="text-align: center;">Ref</th> <th style="text-align: center;">Con</th> </tr> <tr> <td style="text-align: center;">4.30</td> <td style="text-align: center;">0.11</td> <td style="text-align: center;">0.11</td> </tr> <tr> <td style="text-align: center;">17.20</td> <td style="text-align: center;">1.21</td> <td style="text-align: center;">1.23</td> </tr> <tr> <td style="text-align: center;">34.40</td> <td style="text-align: center;">1.75</td> <td style="text-align: center;">1.77</td> </tr> <tr> <td style="text-align: center;">51.60</td> <td style="text-align: center;">1.05</td> <td style="text-align: center;">1.03</td> </tr> </tbody> </table> | GRMS          |  |  | TOTAL<br>Con | RANDOM<br>Ref | RANDOM<br>Con | 2.45 | 1.79 | 1.80 | TONES |  |  | Freq | Ref | Con | 4.30 | 0.11 | 0.11 | 17.20 | 1.21 | 1.23 | 34.40 | 1.75 | 1.77 | 51.60 | 1.05 | 1.03 |
| GRMS                                |   |               |  |  |              |               |               |      |      |      |       |  |  |      |     |     |      |      |      |       |      |      |       |      |      |       |      |      |
| TOTAL<br>Con                        | RANDOM<br>Ref   | RANDOM<br>Con |  |  |              |               |               |      |      |      |       |  |  |      |     |     |      |      |      |       |      |      |       |      |      |       |      |      |
| 2.45                                | 1.79  | 1.80          |  |  |              |               |               |      |      |      |       |  |  |      |     |     |      |      |      |       |      |      |       |      |      |       |      |      |
| TONES                               |   |               |  |  |              |               |               |      |      |      |       |  |  |      |     |     |      |      |      |       |      |      |       |      |      |       |      |      |
| Freq                                | Ref   | Con           |  |  |              |               |               |      |      |      |       |  |  |      |     |     |      |      |      |       |      |      |       |      |      |       |      |      |
| 4.30                                | 0.11  | 0.11          |  |  |              |               |               |      |      |      |       |  |  |      |     |     |      |      |      |       |      |      |       |      |      |       |      |      |
| 17.20                               | 1.21  | 1.23          |  |  |              |               |               |      |      |      |       |  |  |      |     |     |      |      |      |       |      |      |       |      |      |       |      |      |
| 34.40                               | 1.75  | 1.77          |  |  |              |               |               |      |      |      |       |  |  |      |     |     |      |      |      |       |      |      |       |      |      |       |      |      |
| 51.60                               | 1.05  | 1.03          |  |  |              |               |               |      |      |      |       |  |  |      |     |     |      |      |      |       |      |      |       |      |      |       |      |      |
| <b>Mechanical Shock - Operation</b> | MIL-STD-810C/E, Method 516.2, Proc. 1 (30g / Half sine / 3 axis / 6 shocks per axis)  |               |  |  |              |               |               |      |      |      |       |  |  |      |     |     |      |      |      |       |      |      |       |      |      |       |      |      |
| <b>Mechanical Shock - Crash</b>     | X-40G, Y-15G, Z-20G, 11ms, Half Sine, Total 12 shocks   |               |  |  |              |               |               |      |      |      |       |  |  |      |     |     |      |      |      |       |      |      |       |      |      |       |      |      |
| <b>Bench Handling Shock</b>         | MIL-STD-810F, Method 516.5, Procedure VI  |               |  |  |              |               |               |      |      |      |       |  |  |      |     |     |      |      |      |       |      |      |       |      |      |       |      |      |
| <b>Rain</b>                         | MIL-STD-810E Method 506.3 procedure I   |               |  |  |              |               |               |      |      |      |       |  |  |      |     |     |      |      |      |       |      |      |       |      |      |       |      |      |
| <b>Dust</b>                         | MIL-STD-810E Method 510.3   |               |  |  |              |               |               |      |      |      |       |  |  |      |     |     |      |      |      |       |      |      |       |      |      |       |      |      |
| <b>Salt Atmosphere</b>              | MIL-STD-810E, Method 509.3, Procedure I   |               |  |  |              |               |               |      |      |      |       |  |  |      |     |     |      |      |      |       |      |      |       |      |      |       |      |      |
| <b>Bonding</b>                      | ≤2.5 mΩ   |               |  |  |              |               |               |      |      |      |       |  |  |      |     |     |      |      |      |       |      |      |       |      |      |       |      |      |
| <b>EMI / RFI</b>                    | MIL-STD-461B/C Part: 5 (CE01, CE03, CE07, RE02, CS01, CS02, CS06, RS02, RS03)   |               |  |  |              |               |               |      |      |      |       |  |  |      |     |     |      |      |      |       |      |      |       |      |      |       |      |      |

| <b>Power Supply</b>      |  |
|--------------------------|--|
| <b>Input Voltage</b>     | 22-32 VDC (28 VDC Typ.) per MIL-STD-704D   |
| <b>Power consumption</b> | < 30 W @ 28 VDC (warm-up)<br>< 16 W @ 28 VDC @ 25°C (steady-state)<br>< 20 W @ 28 VDC @ -25°C (steady-state) |

| <b>Reliability, Maintainability, Testability</b> |  |
|--|--|
| <b>MTBF</b>                                      | > 16,000 hours @ 30°C, ARW, MIL-HBK-217F (for C/A GPS receiver)<br>> 3,700 hours @ 30°C, ARW, MIL-HBK-217F (for P/Y GB-GRAM) |
| <b>MTTR – O Level</b>                            | 12 minutes to replace failed unit (including warm-up time)   |
| <b>BIT (Built In Test)</b>                       | On-line BIT – Automatic, Covers > 90% of all failures  |

| <b>Dimensions &amp; Weight</b>                                |   |                         |          |   |          |   |          |
|---|---|-------------------------|----------|---|----------|---|----------|
| <b>Dimensions</b>   | 175 mm (d) x 132 mm (w) x 56 mm (h)   |                         |          |   |          |   |          |
| <b>Weight</b>   | <table border="0" style="width: 100%;"> <tr> <td style="width: 70%;">C / A code GPS receiver</td> <td style="text-align: right;">≤ 1.2 Kg</td> </tr> <tr> <td>C / A code GPS receiver and LAN / 1553 board:</td> <td style="text-align: right;">≤ 1.3 Kg</td> </tr> <tr> <td>P / Y code GPS receiver, back up battery and LAN / 1553 board</td> <td style="text-align: right;">≤ 1.5 Kg</td> </tr> </table> | C / A code GPS receiver | ≤ 1.2 Kg | C / A code GPS receiver and LAN / 1553 board: | ≤ 1.3 Kg | P / Y code GPS receiver, back up battery and LAN / 1553 board | ≤ 1.5 Kg |
| C / A code GPS receiver                                       | ≤ 1.2 Kg  |                         |          |   |          |   |          |
| C / A code GPS receiver and LAN / 1553 board:                 | ≤ 1.3 Kg  |                         |          |   |          |   |          |
| P / Y code GPS receiver, back up battery and LAN / 1553 board | ≤ 1.5 Kg  |                         |          |   |          |   |          |

All specs are @ 25°C, quiescent conditions and sea level ambient unless otherwise specified

### Principles of Operation

The following block diagrams depict the operation of the AR51A-09. The unit includes Rubidium Standard and accepts Input from internal GPS receiver, external 1PPS or external TOD (H.Q.). All outputs are derived from the internal Rubidium Clock, which is phase locked by a digital PLL to the selected input. Thus, the Rubidium Clock - frequency and time - follows the GPS on the long term average. If GPS reception is lost for short or long periods of time the Rubidium Clock shall maintain accurate time and frequency with no phase interruption.

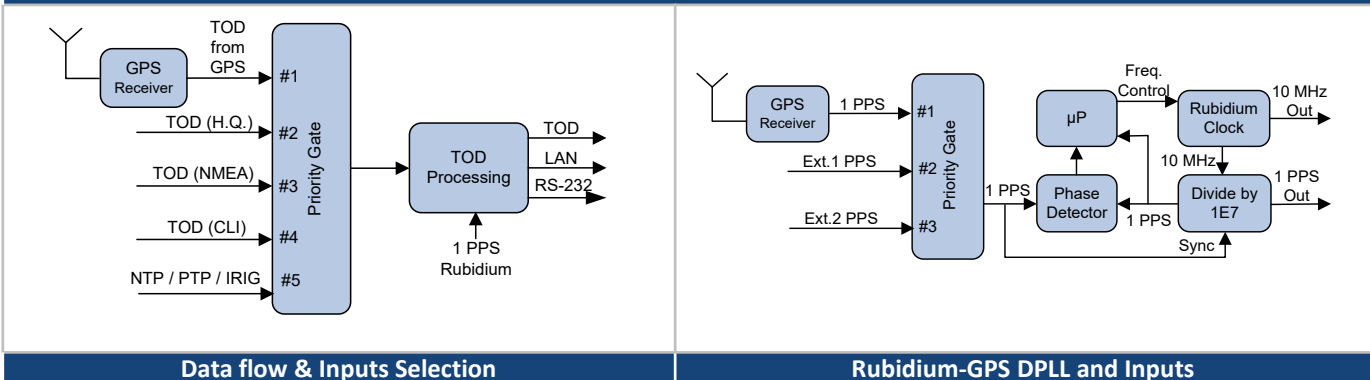

### Typical Performance Plots

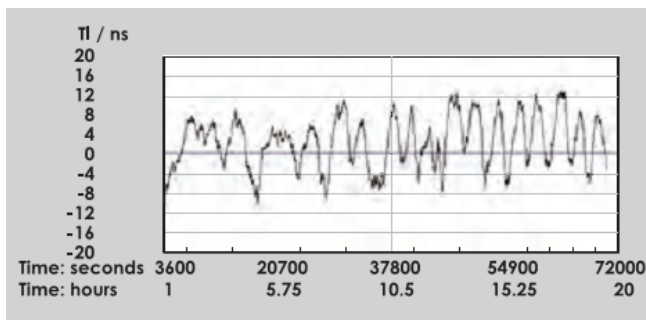

Typical time error fluctuations when disciplined to GPS

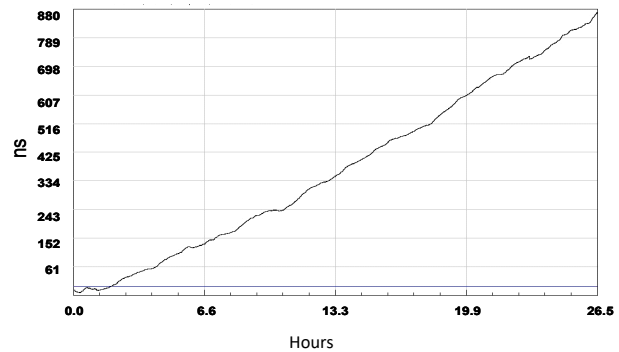

Typical time error in Holdover (without GPS)

All specs are @ 25°C, quiescent conditions and sea level ambient unless otherwise specified

**Graphic User Interface (GUI) Software for PC (Option)**

GUI for PC is available: parameters settings (like: time, date, unit configuration etc'), monitoring (like: BIT status) and data presentation (like: time, date, position etc')

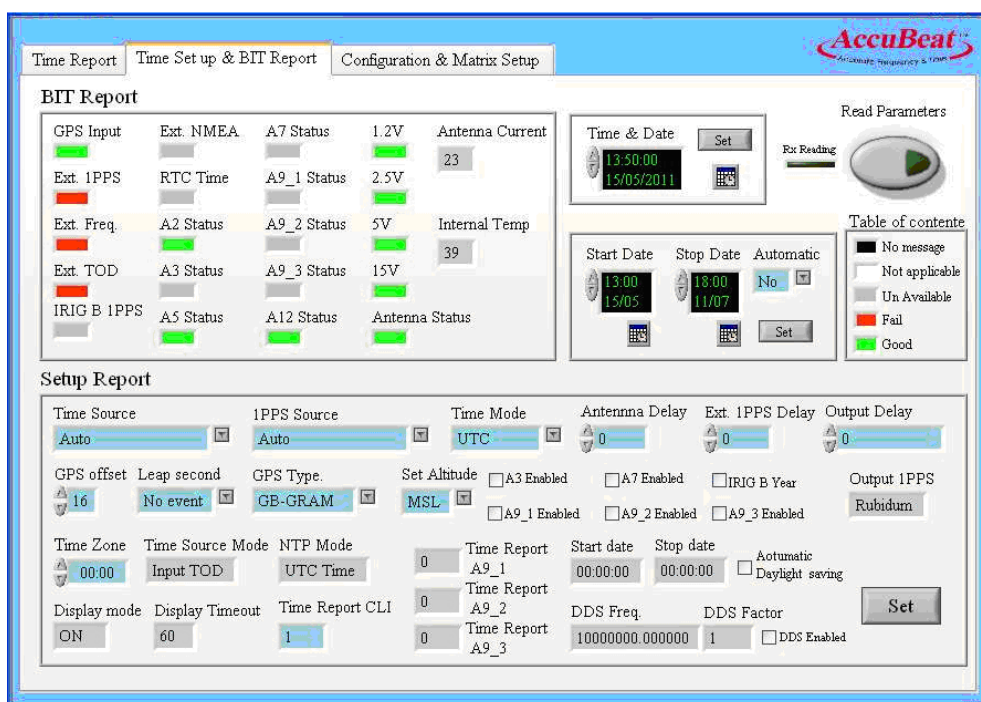
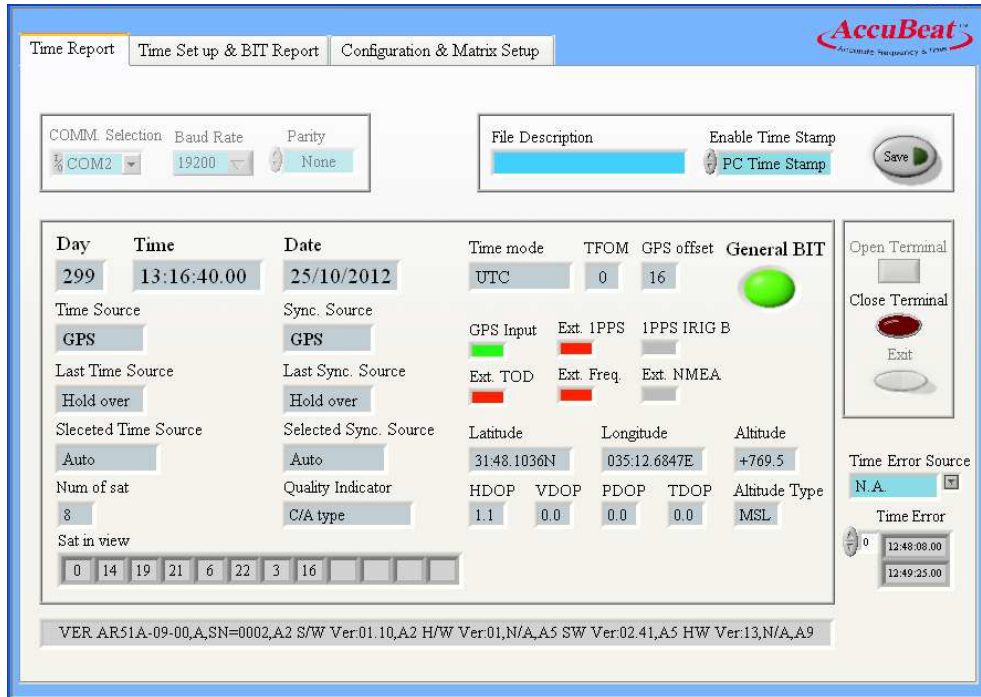

All specs are @ 25°C, quiescent conditions and sea level ambient unless otherwise specified

**Graphic User Interface (GUI) Software for PC (Option)**

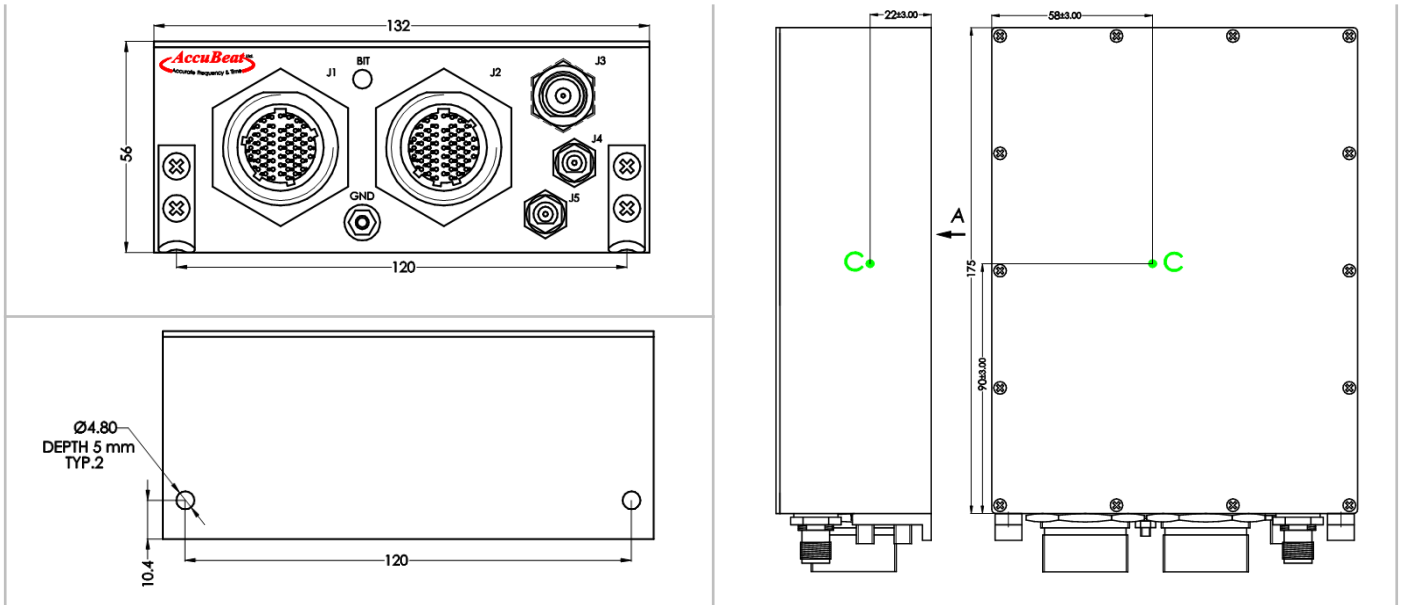

| Electrical ICD |  |          |
|----------------|--|----------|
| Connector      | Description  | I/O      |
| J1             | 1PPS RS422 outputs x 4<br>1PPS RS422 Input x 1<br>1PPS TTL output x 1<br>Have Quick outputs x 2<br>Have Quick input x 1<br>CLI RS-232 (Rx, Tx)<br>LAN / MuxBus<br>Over all BIT indication x 1<br>P (Y) code GPS receiver crypto keys<br>Power supply | In / Out |
| J2             | 1PPS RS422 output x 1<br>1PPS PTTI input x 1<br>1PPS PTTI outputs x 17<br>Have Quick output x 2<br>CLI RS422 x 1   | In / Out |
| J3             | GPS antenna input<br>1.5GHz, TNC, Female<br>5V DC – out for active antenna   | In / Out |
| J4             | 1PPS, TTL / 50Ω, SMA, Female   | Out      |
| J5             | 10MHz, Sine-wave, 8 ± 2dBm, 50Ω, SMA, Female   | Out      |

All specs are @ 25°C, quiescent conditions and sea level ambient unless otherwise specified

**HOW TO ORDER**

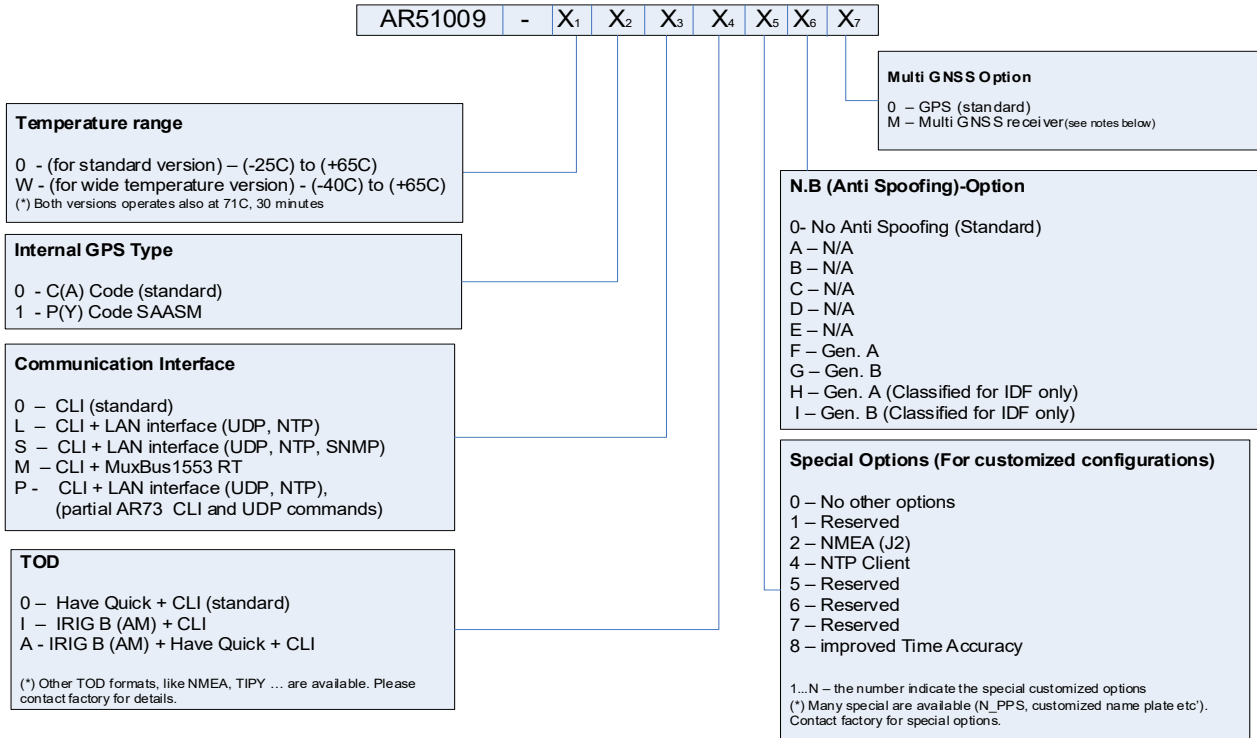

Please note that not all combinations may be possible. Please contact AccuBeat for further information

**Notes:**

1. Multi GNSS supports GPS, GLONAS, GALILEO and BEIDU constellation.

**ACCESSORIES**

For Accessories like GPS antenna, antenna cable, tray with vibration isolator, GUI etc. contact factory.

AccuBeat Ltd, 5 Ha'Marpeh St., Har Hotzvim, P.O.Box 45012, Jerusalem 91450, Israel  
 Tel: +972-2-5868330, Fax: +972-2-5868550, E-Mail: marketing@accubeat.com  
<http://www.accubeat.com>